

Anodi per motori VOLVO

VOLVO

Anodi per scambiatori calore/collettore

Zinco	Zinco + ottone	↔ mm	Rif. originale	Filetto
43.540.00	-	∅ 15,5x40+10	800476	7/16"
43.540.01	-	∅ 15x30	838929	M8
43.271.40	-	∅ 15x30+10	838929	7/16"
-	43.540.10	67x15 ∅	43.540.00 + ottone	1/2" BSPT
-	43.540.11	57x16 ∅	43.271.40 + ottone	1/2" BSPT
43.540.15	-	∅ 16x13+10	-	5/16"
43.540.16	-	∅ 26x44+8	823661	3/8"
-	43.547.00	∅ 25/40x45	-	3/8"

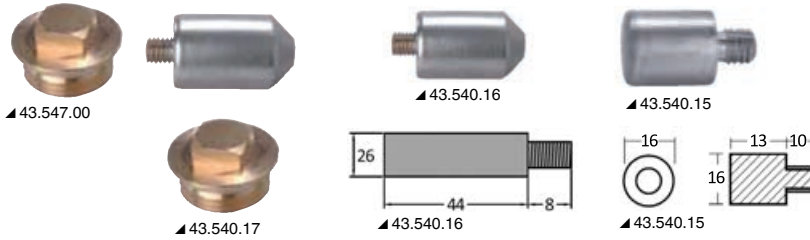
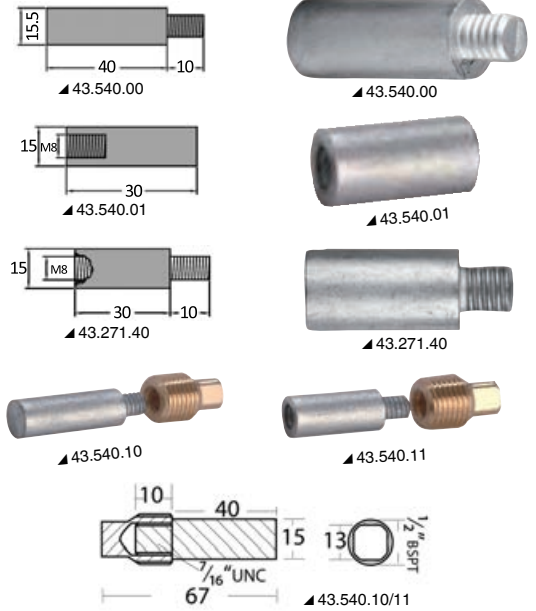

Piede Duo Prop (anche piede Cobra Omc)

Zinco	Alluminio	Magnesio	Riferimento originale
43.554.11	43.554.09	43.554.10	3855411-2

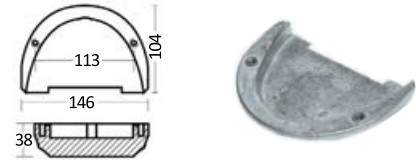

Anodo per Volvo Penta serie DP

Zinco	Alluminio	Magnesio	Rif. originale
43.554.13	43.554.33	43.554.34	3588746/3588748/3588750
43.554.14	43.554.44	43.554.54	3589875/3589876

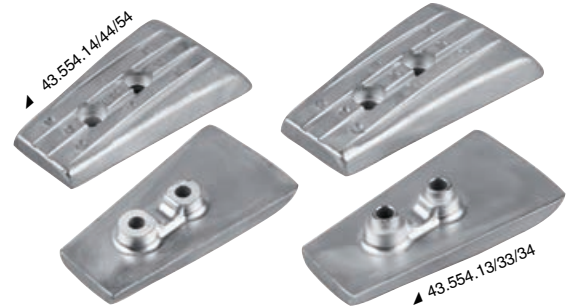
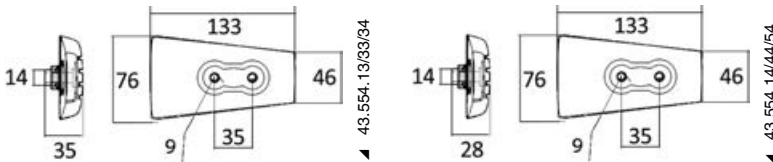

Volvo SX/DPS (anche piede Cobra OMC)

Zinco	Alluminio	Magnesio	Rif. originale
43.541.30	43.541.31	43.541.32	3854130 / 3855610

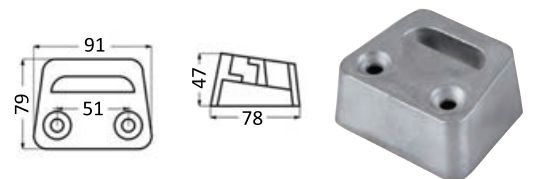

Barra universale per piedi tipo 250/270/280

Zinco	Alluminio	Magnesio	Riferimento originale
43.550.00	43.550.01	43.550.02	832598-7



Piedi DPX

Zinco	Alluminio	Magnesio	Riferimento originale
43.549.05	43.549.15	43.549.25	873395-8

